

## GSAF Series – Suction Cup Dimensional Data (Unit: mm)

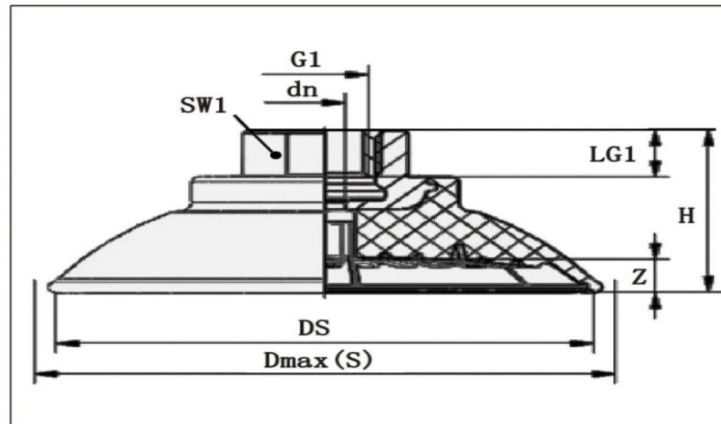

Model	G1	dn	SW1	LG1	H	Z	DS	Dmax (S)
GSAF-30	G1/4	4	17	7	20	3	31	34
GSAF-40	G1/4	4	17	7	22	4	42	46
GSAF-50	G3/8	7	22	10	28	5	51	56
GSAF-60	G3/8	7	22	10	31	6	61	67
GSAF-80	G3/8	7	22	10	35	7.6	80	89
GSAF-100	G3/8	7	22	10	36	9.5	102	110
GSAF-125	G3/8	7	22	10	43	12.5	125	135